

Purchase List	
QTY	DESCRIPTION
1	Plywood 3/8 x 48 x 48 (4'x4' Sheet)
1	Plywood 5/8 x 48 x 96 (4'x8' Sheet)
2	Pine 2 x 4 x 96
1	Pressure Treated 2x4x96
1	Foam 2 x 48 x 96 (4'x8' Sheet)

NOTE: 5/8" or 21/32" plywood will work

Parts List					
ITEM	QTY	DESCRIPTION	Thick	Width	Length
1	2	Base Front & Rear	1.500 in	3.500 in	20.000 in
2	2	Base Side	1.500 in	3.500 in	28.000 in
3	1	Floor Panel	0.625 in	20.000 in	28.000 in
4	1	Front Panel	0.625 in	19.000 in	21.250 in
5	1	Rear Panel	0.625 in	19.000 in	21.250 in
6	2	Side Panel	0.625 in	19.000 in	28.000 in
7	2	Roof Panel	0.625 in	19.813 in	32.813 in
8	3	Rear Panel	0.625 in	10.625 in	21.250 in
9	2	Wind Break Side	0.625 in	4.500 in	15.500 in
10	1	Wind Break Top	0.625 in	6.000 in	16.000 in
11	4	Trim Insulation	0.375 in	3.000 in	8.375 in
12	4	Trim Door	0.500 in	1.500 in	11.000 in
13	2	Roof Guide	0.500 in	1.500 in	20.000 in
14	4	Trim Peak	0.500 in	1.500 in	19.250 in
15	2	Trim Corner RH	1.500 in	1.500 in	20.000 in
16	2	Trim Corner LH	1.500 in	1.500 in	20.000 in
17	2	Trim Side Bottom	0.500 in	1.500 in	27.250 in
18	2	Trim Front & Rear Bottom	0.500 in	1.500 in	19.250 in
19	2	Trim Front & Rear Top	0.500 in	1.500 in	18.500 in
20	1	Insulation Bottom	2.000 in	17.000 in	25.000 in
21	1	Insulation Front	2.000 in	15.875 in	20.000 in
22	1	Insulation Rear	2.000 in	15.875 in	20.000 in
23	2	Insulation Rear	2.000 in	15.875 in	24.000 in
24	2	Insulation Ceiling	2.000 in	13.688 in	21.000 in
25	2	Liner Side	0.375 in	15.875 in	23.250 in
26	1	Liner Rear	0.375 in	15.875 in	16.000 in
27	1	Liner Front	0.375 in	15.875 in	16.000 in
28	28	Screw Deck Mate			3.000 in
29	56	Screw Deck Mate			2.000 in
30	6	Screw Deck Mate			1.000 in

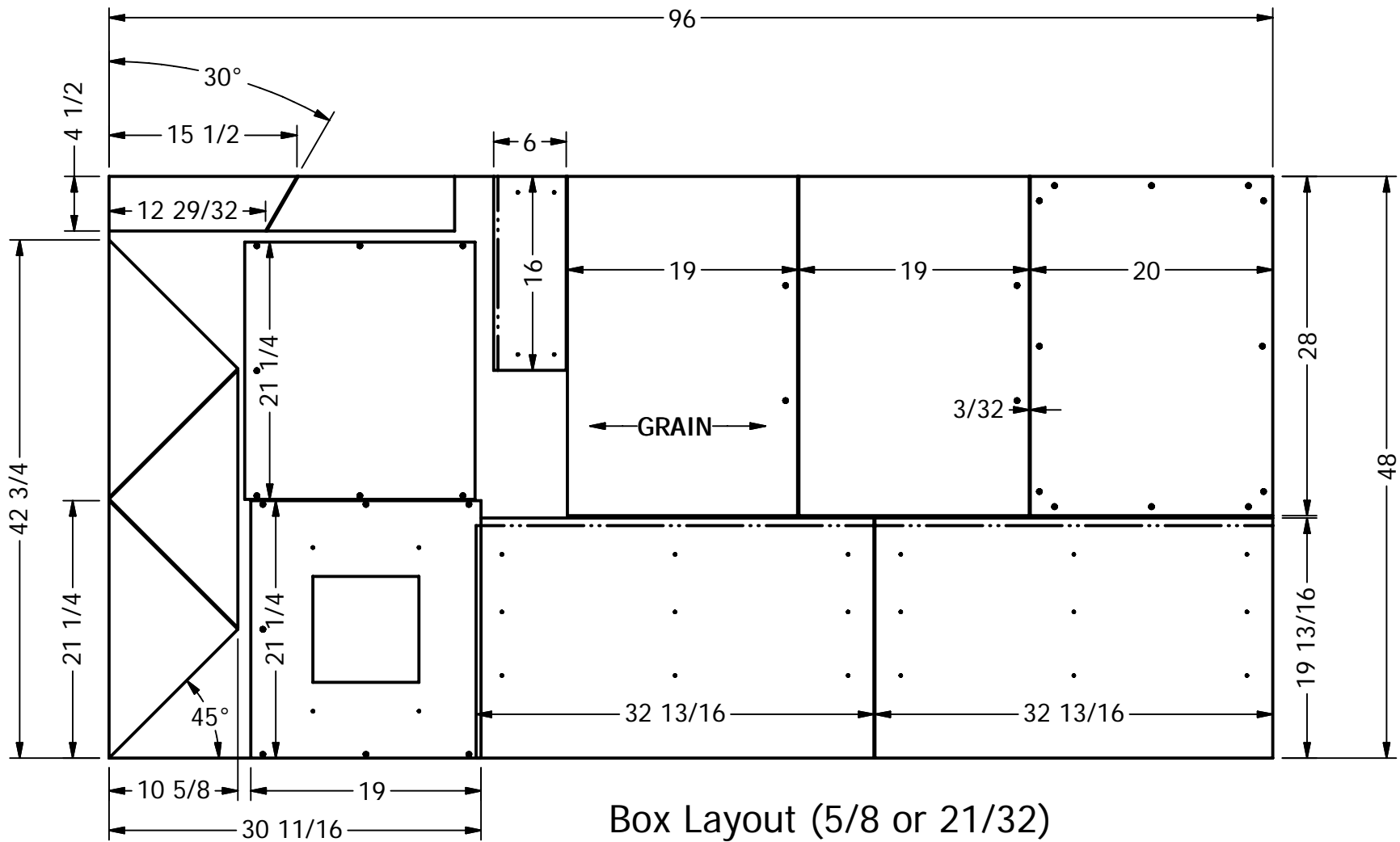

CUT (2) TWO 19 1/2" PIECES FOR THE CORNER TRIM
 THEN RIP REMAINDER OF BOARD INTO (5) 1/2" SLATS AND FOLLOW THE CUT GUIDE BELOW

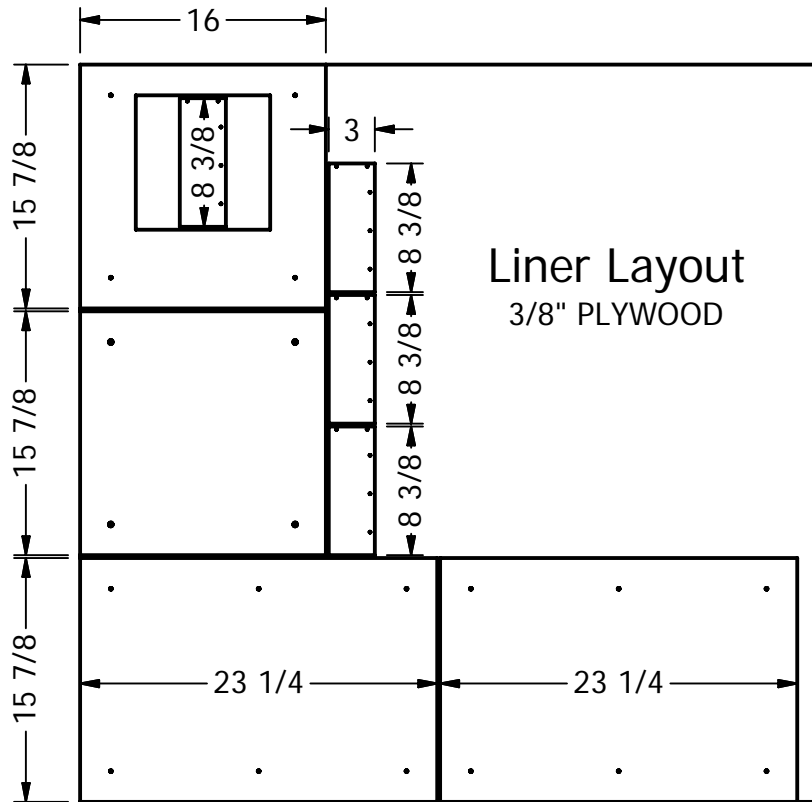
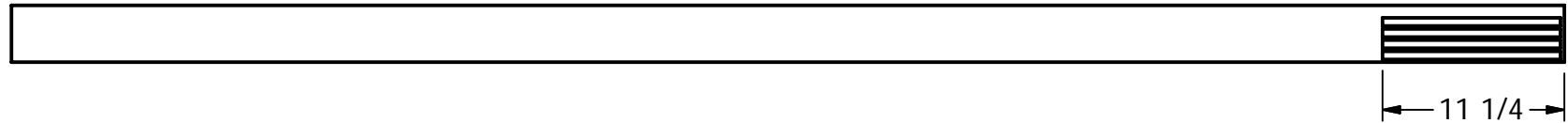

SLAT #1 BOTTOM TRIM (2) pcs 27 1/2"



SLAT #2 ROOF GUIDE LIP (2) pcs 20 1/4"



SLAT #3 FRONT & REAR BOTTOM TRIM (2) pcs 19 1/2"



SLAT #4 PEAK TRIM (3) pcs 19 1/2" [WARNING: USE MITER CUTS]



SLAT #5 PEAK TRIM (1) pc 19 1/2"

FRONT & REAR TOP TRIM (2) pcs 18 3/4"
 [WARNING: USE MITER CUTS]

NOTE:

Sizes above are 1/4" longer than needed, cut to fit at final assembly.

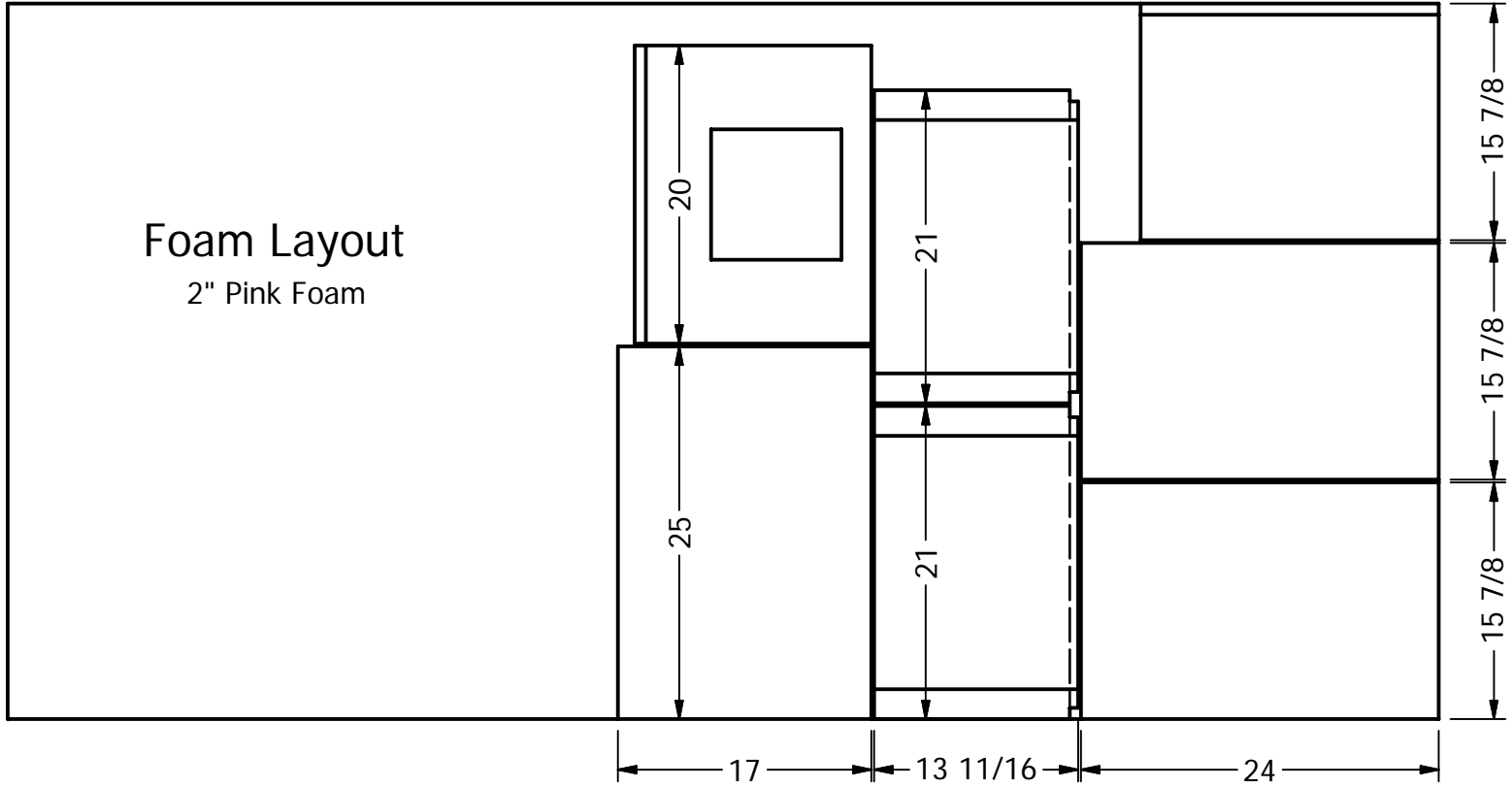

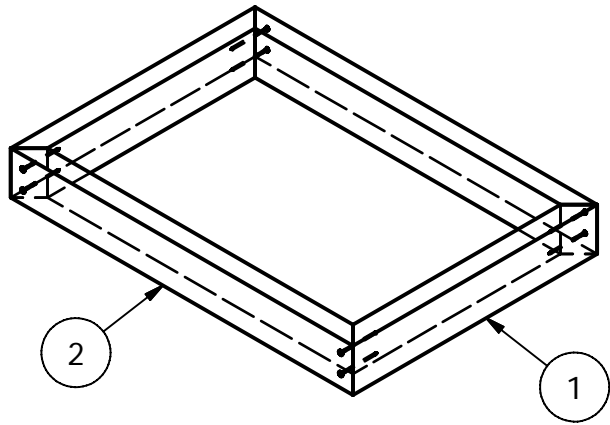

BASE ASSEMBLY

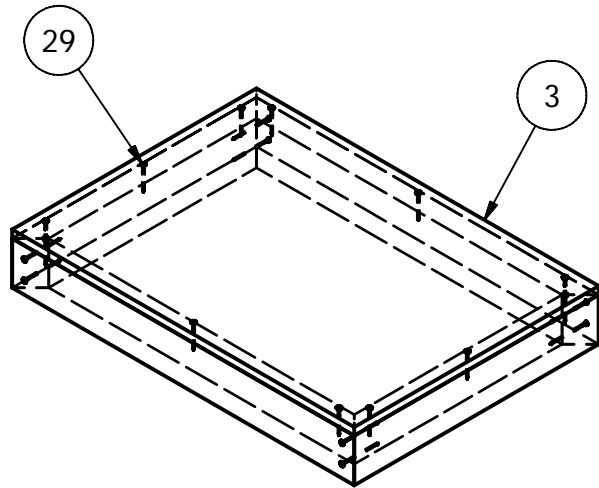

FRONT PANEL DETAILS

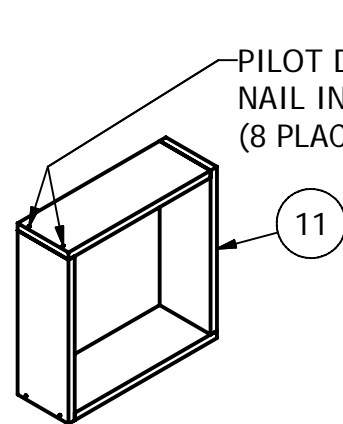
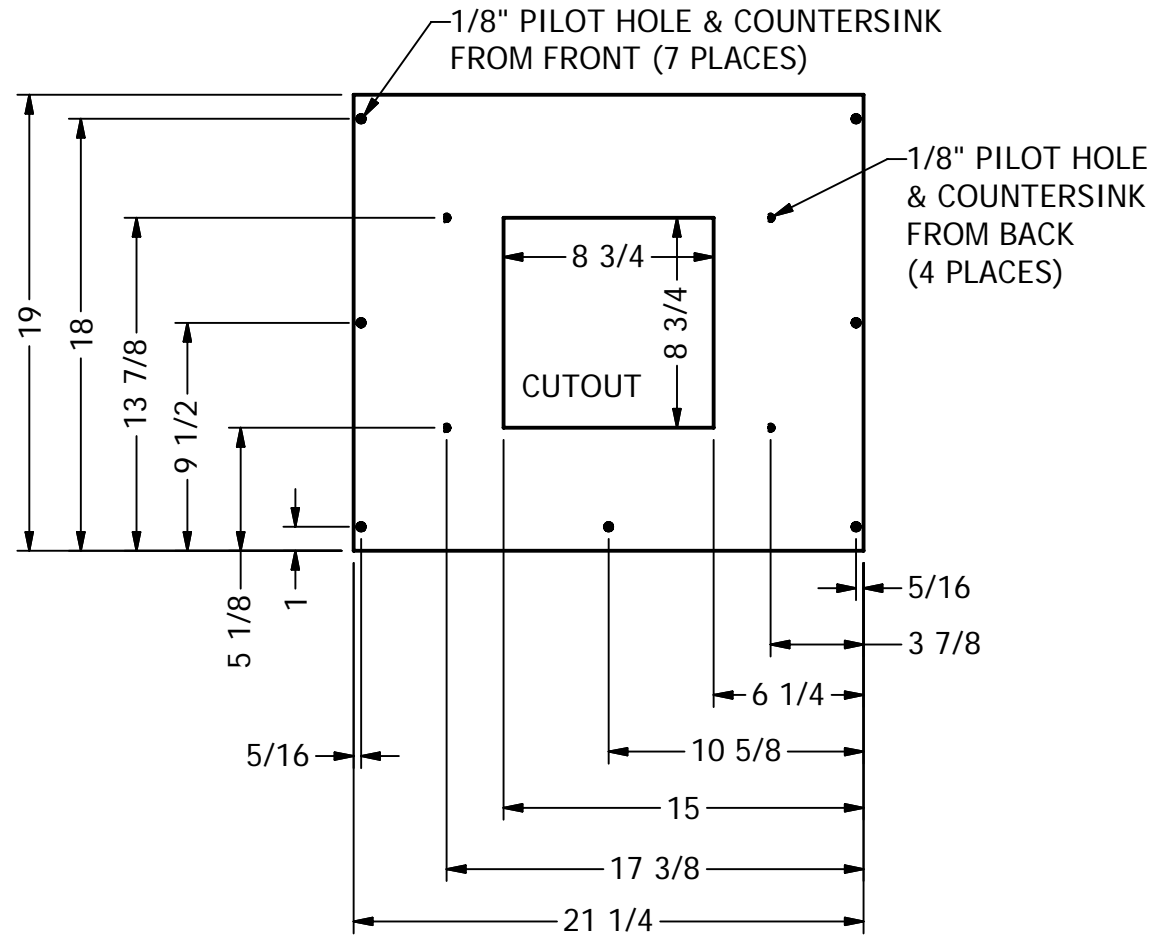

PILOT DRILL AND FINISH NAIL INSULATION TRIM (8 PLACES)

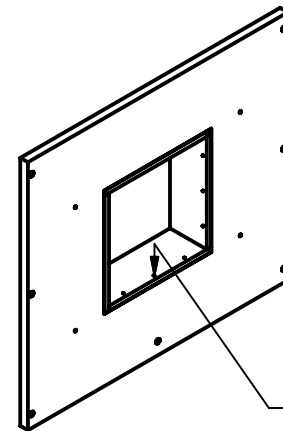

PILOT DRILL & FINISH NAIL TO FRONT PANEL (12 PLACES)

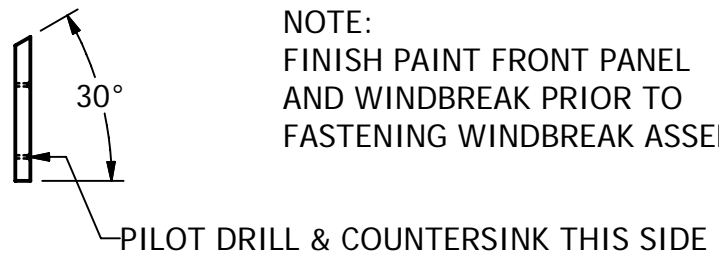
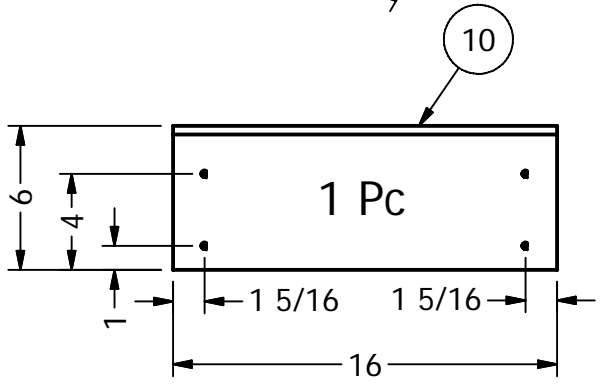
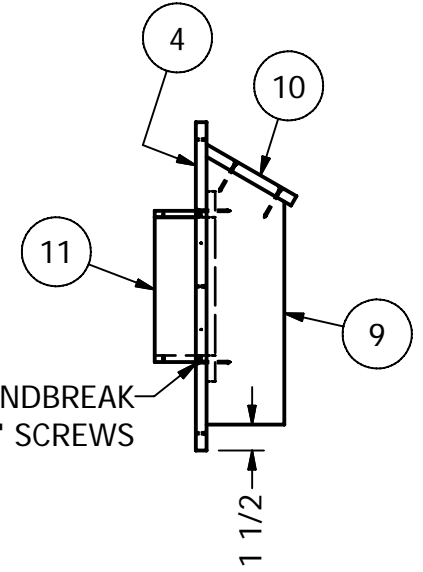
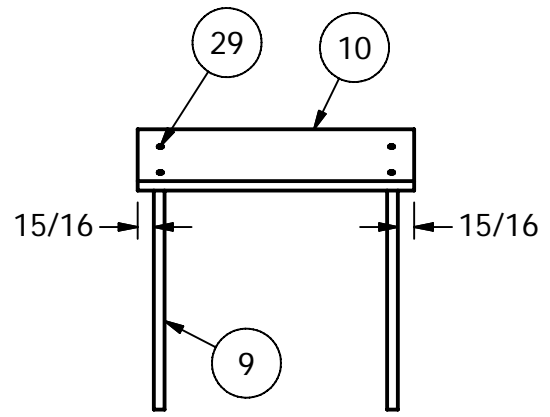
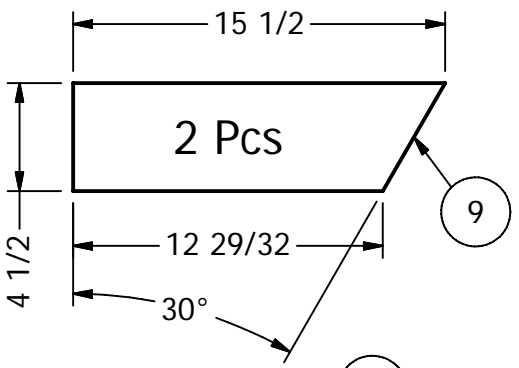
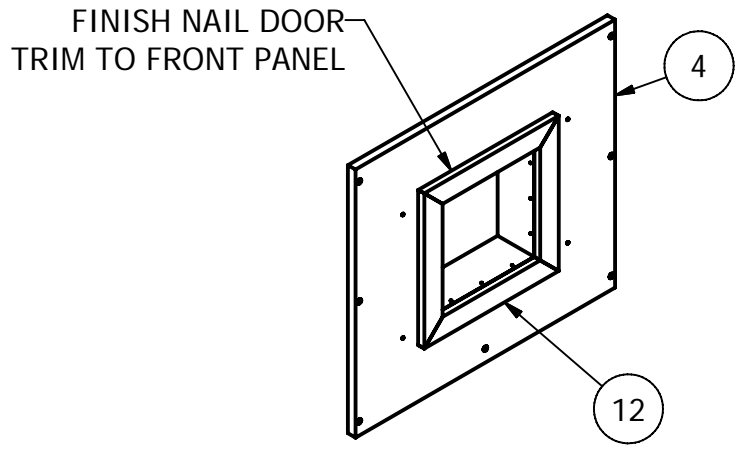
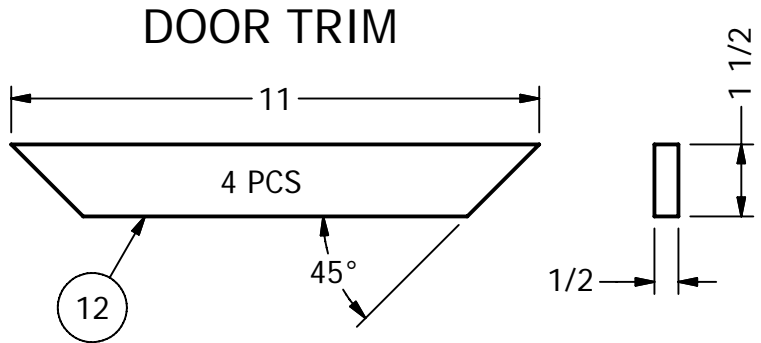

MATCH DRILL WINDBREAK & FASTEN w/ 2" SCREWS

NOTE:
FINISH PAINT FRONT PANEL
AND WINDBREAK PRIOR TO
FASTENING WINDBREAK ASSEMBLY

ASSEMBLE FRONTWALL AND SIDE

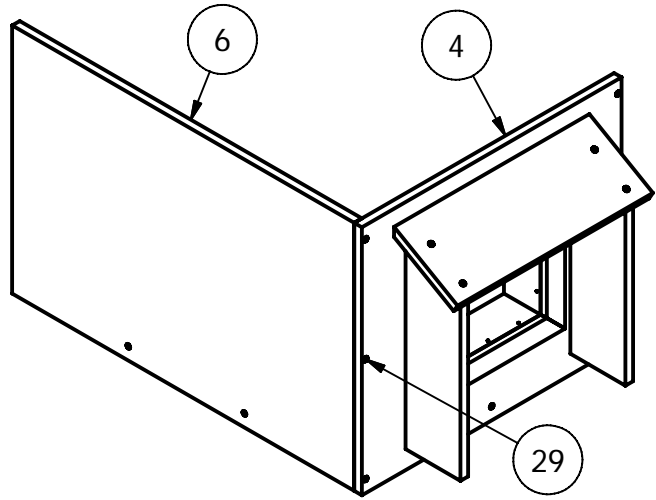

ASSEMBLE BACKWALL AND SIDE

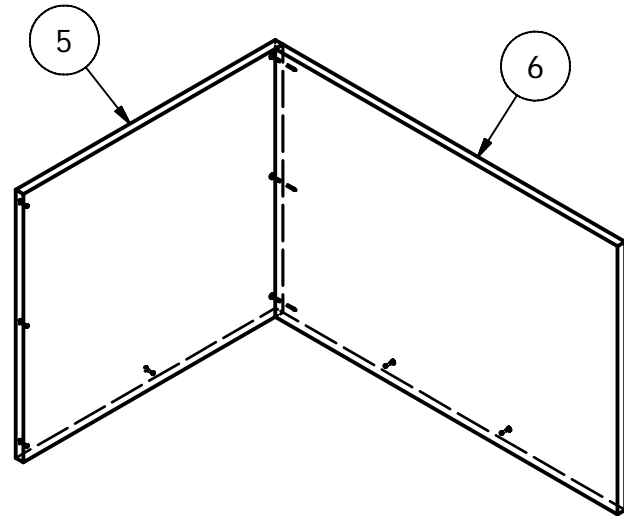

CLAMP SIDE ASSEMBLIES TOGETHER AND FASTEN TO BASE

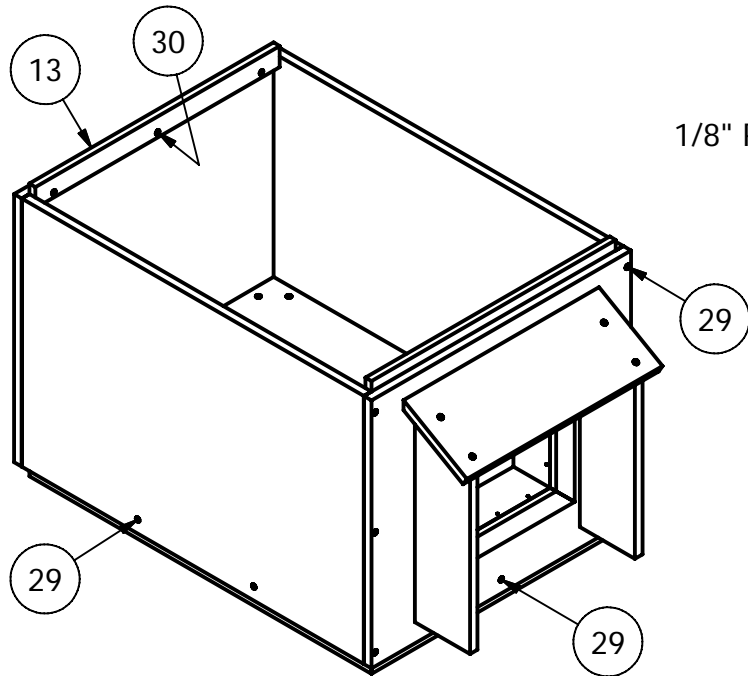

1/8" PILOT & COUNTERSINK

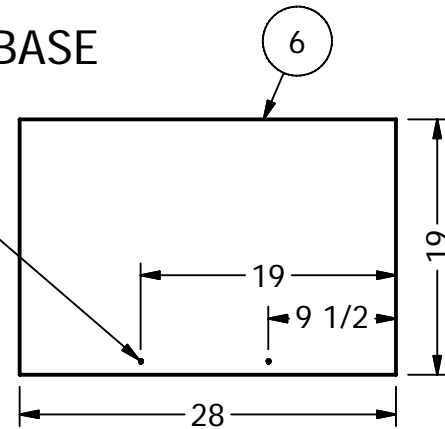

1/8" PILOT & COUNTERSINK

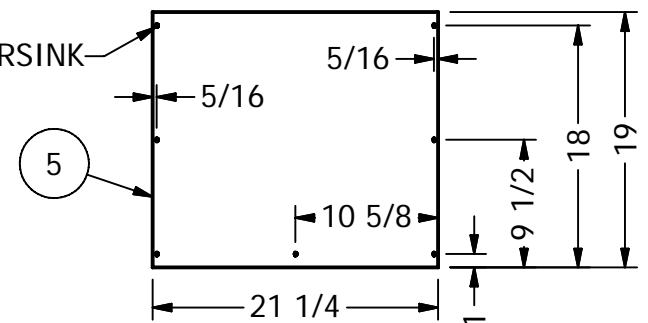

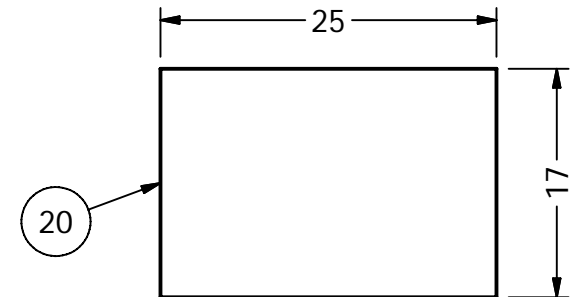
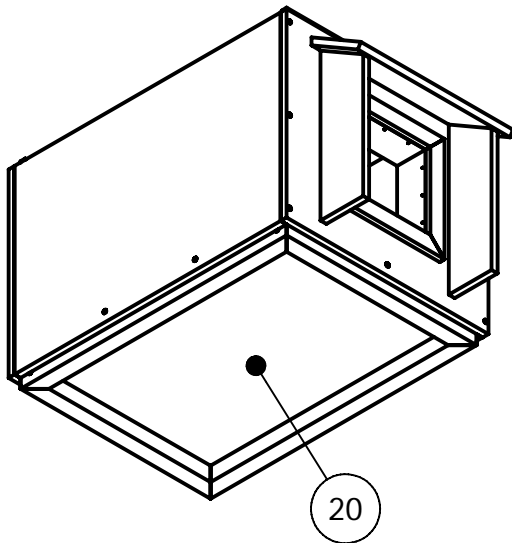
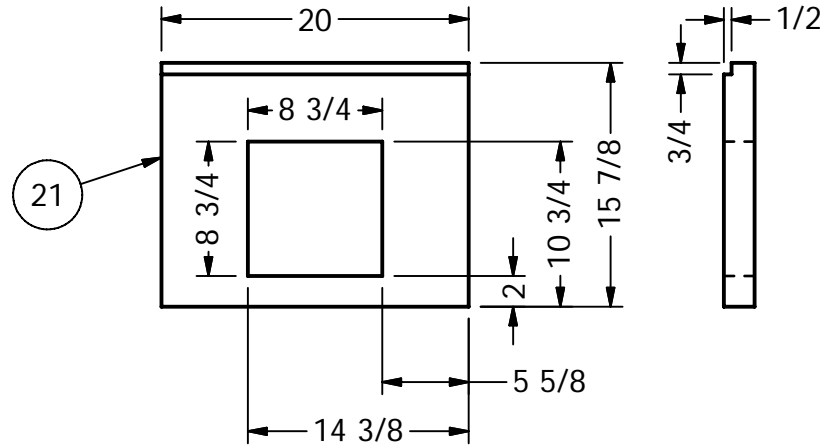
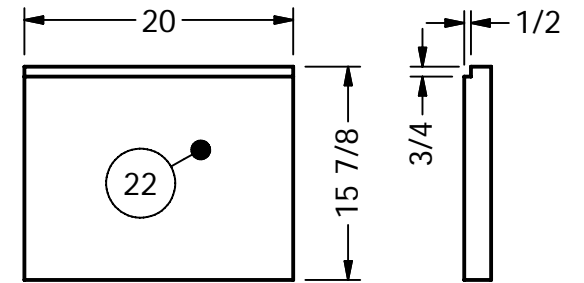
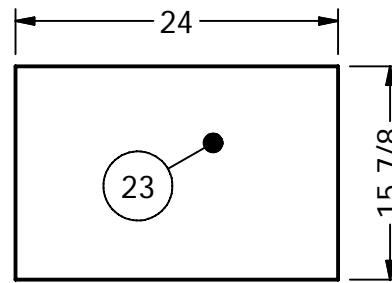
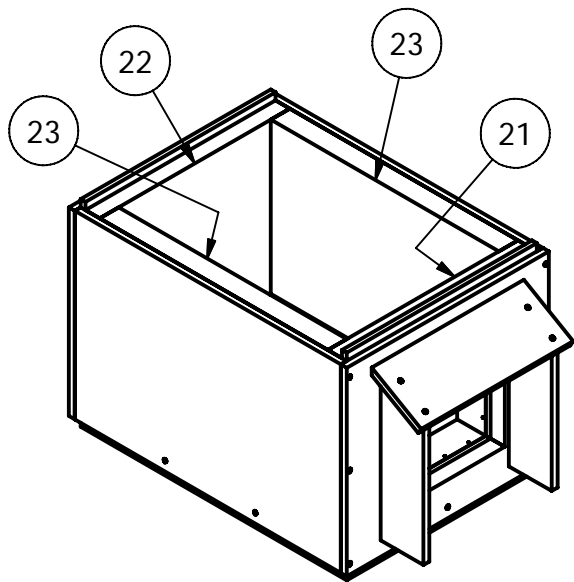

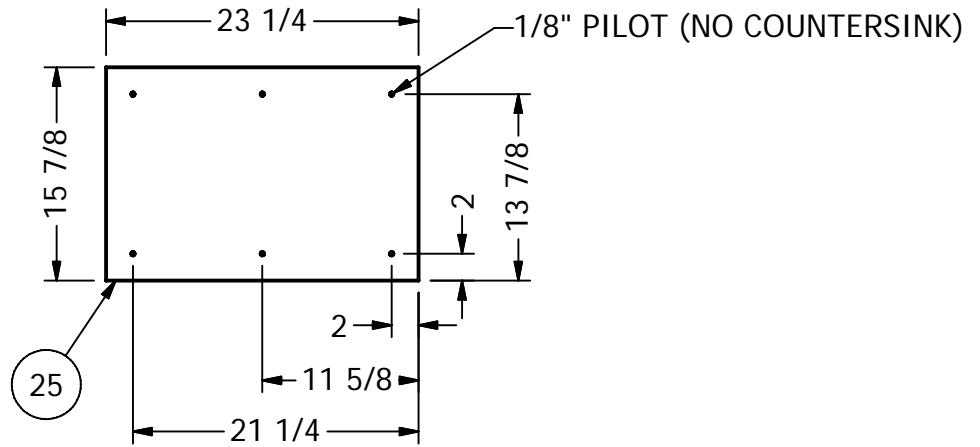
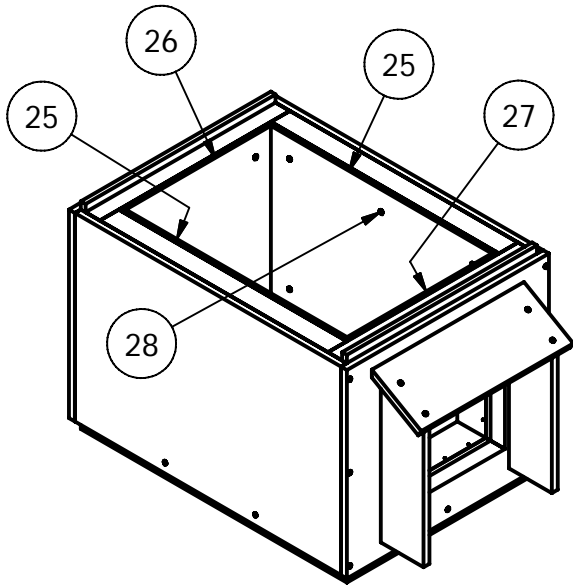

WARNING:
TIGHTEN SCREWS ONLY UNTILL SNUG
OVERTIGHTENING WILL CAUSE POINT OF
SCREW TO PROTRUDE OUTSIDE OF BOX

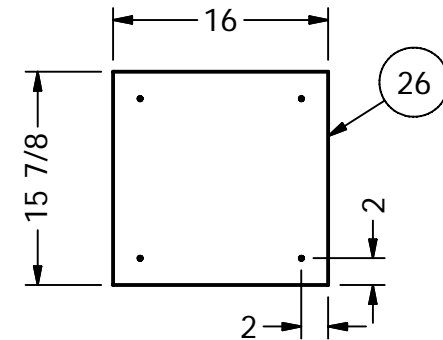
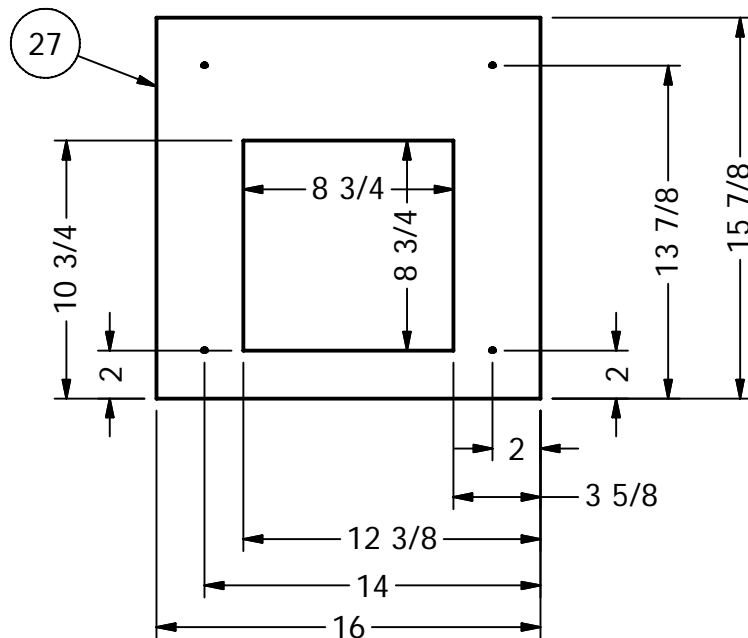

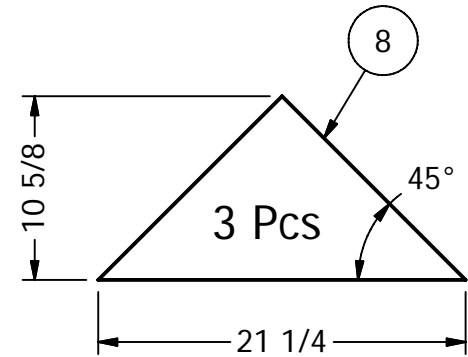
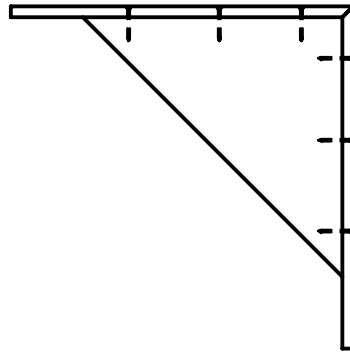
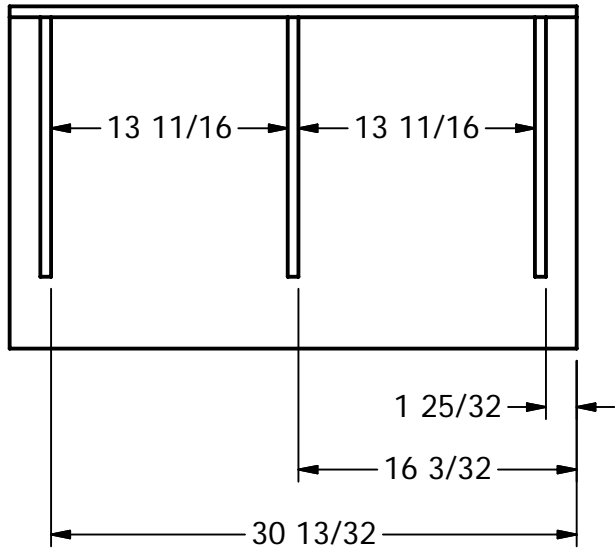
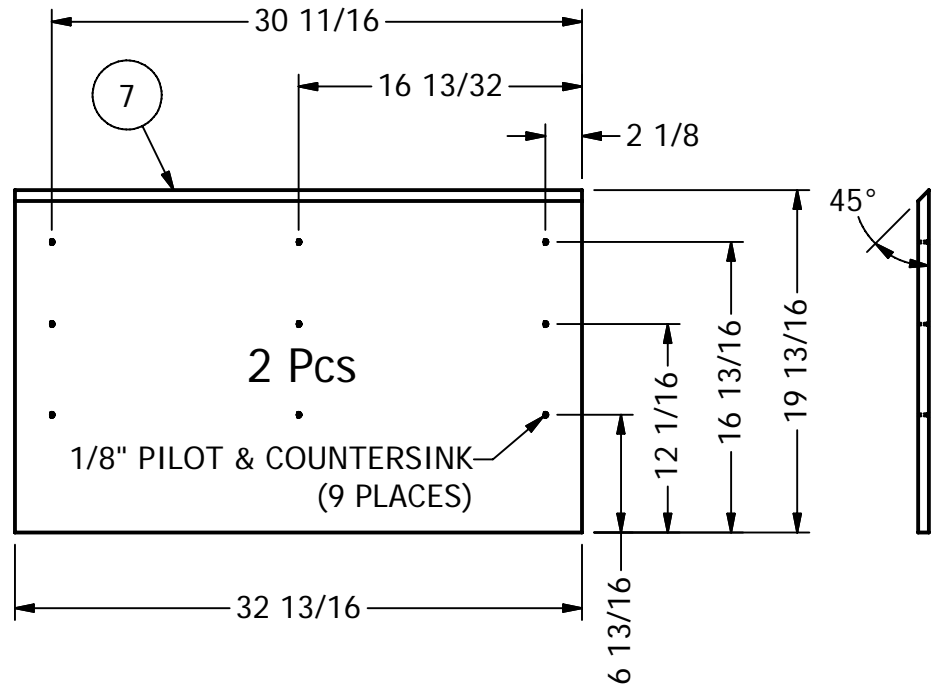
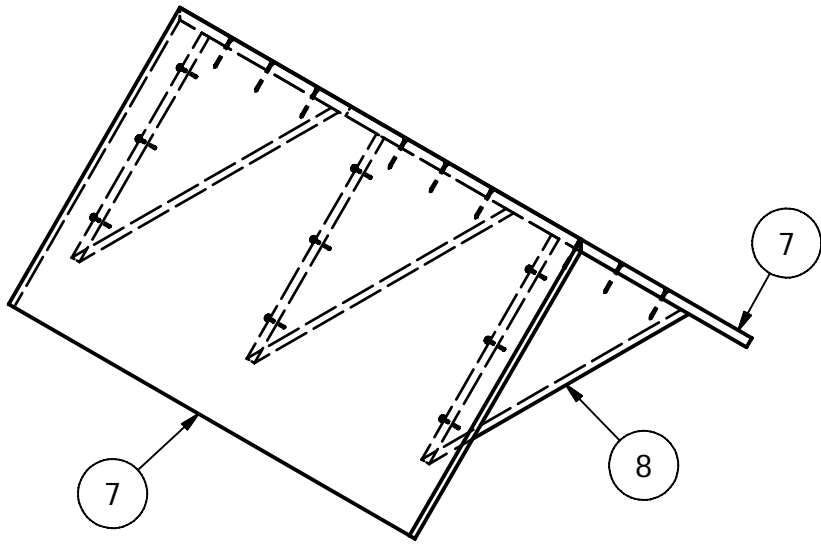

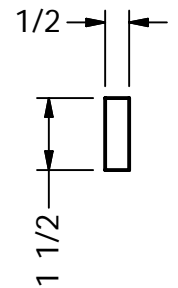
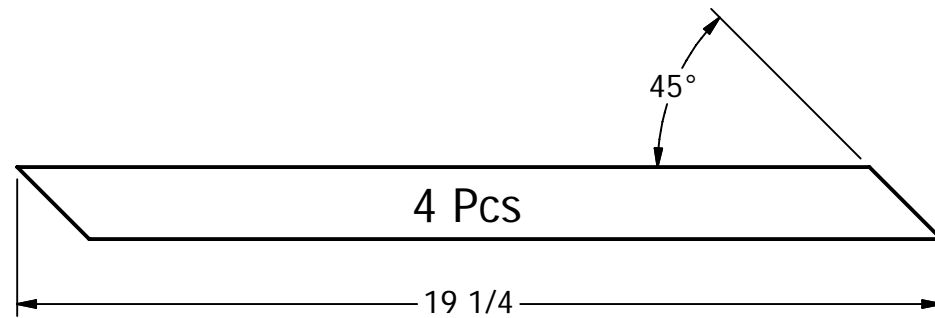
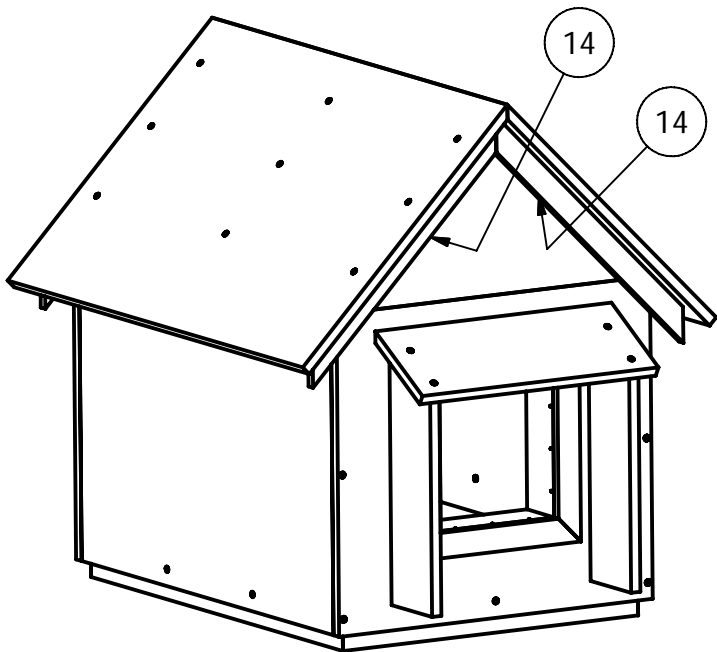
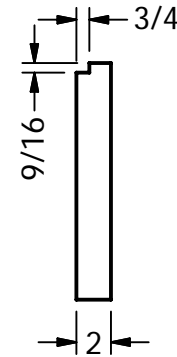
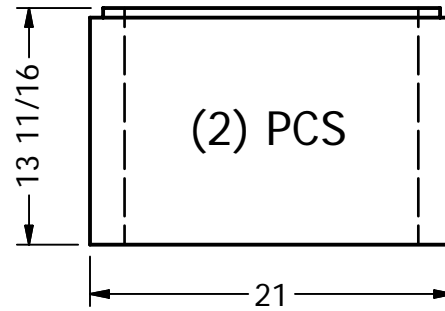
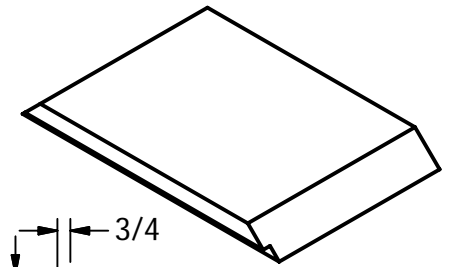
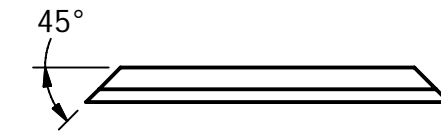
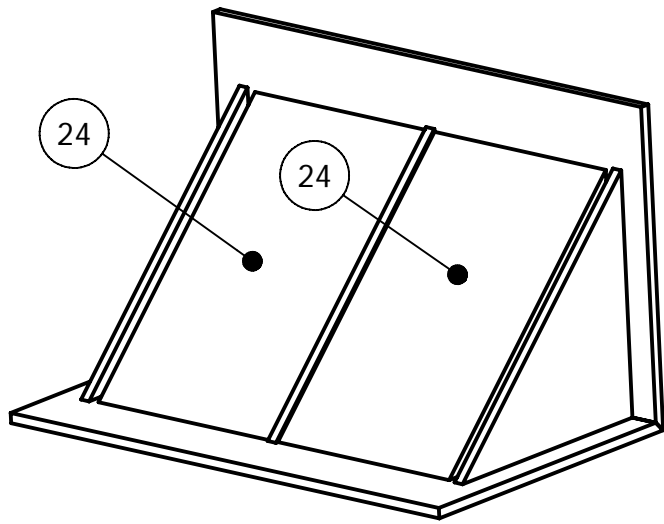

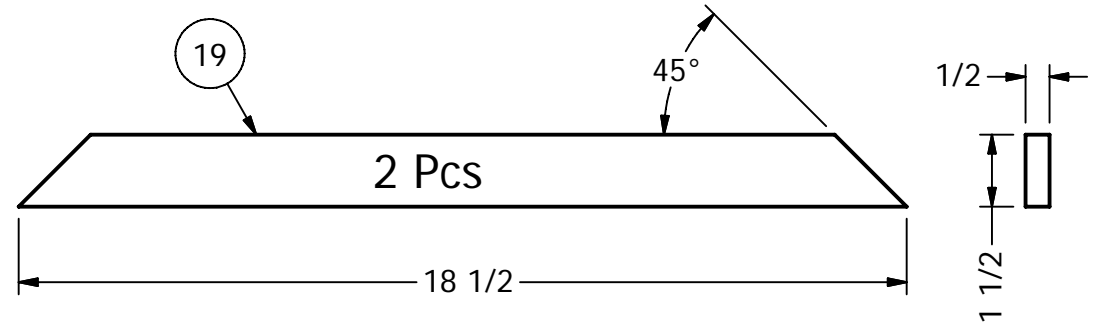
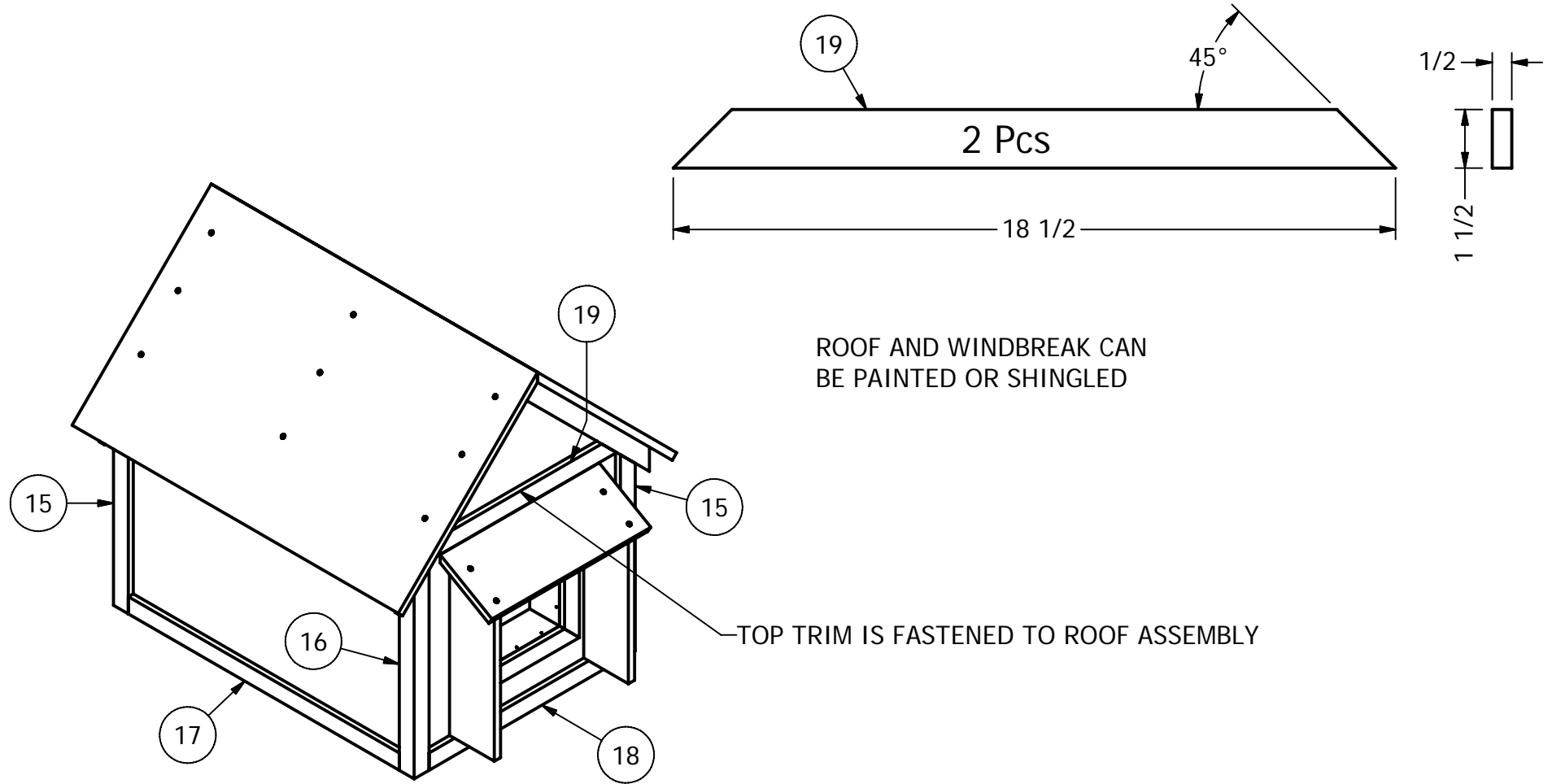

ROOF AND WINDBREAK CAN BE PAINTED OR SHINGLED

TOP TRIM IS FASTENED TO ROOF ASSEMBLY

